



JORDAN VALVE

3170 Wasson Road • Cincinnati, OH 45209 USA
Phone 513-533-5600 • Fax 513-871-0105
info@richardsind.com • www.jordanvalve.com

I & M Mark 63/64

Installation & Maintenance Instructions Supplement for Mark 63 and Mark 64

Warning: Jordan Valve pressure regulators must only be used, installed and repaired in accordance with these Installation & Maintenance Instructions. Observe all applicable public and company codes and regulations. In the event of leakage or other malfunction, call a qualified service person; continued operation may cause system failure or a general hazard. Before servicing any valve, disconnect, shut off, or bypass all pressurized fluid. Before disassembling a valve, be sure to release all spring tension.

Note: The Mark 63 and Mark 64 Differential Regulators have the same valve body and seating construction as the Mark 60. This supplemental presents only those instructions necessary to maintain the topworks, and is to be used in conjunction with the Installation and Maintenance Instructions for the Mark 60 for other maintenance procedures.

Installation

The installation instructions for the Differential Regulator are identical to the instructions for the Mark 60 with the following additions:

- Connect the reference pressure feedback line to the threaded port in the spring housing. The Flow-Thru Spring Housing has full size threaded connections so that the reference fluid can be piped directly through the Spring Housing.
- Trapped air in the upper section of the Spring Housing can be bled off by opening the Bleed Port or Bleed Valve (if supplied) or by loosening the Seat Nut on the Mark 63 and 63C or by loosening the Packing Nut on the Mark 63H.

Seal Nut Type

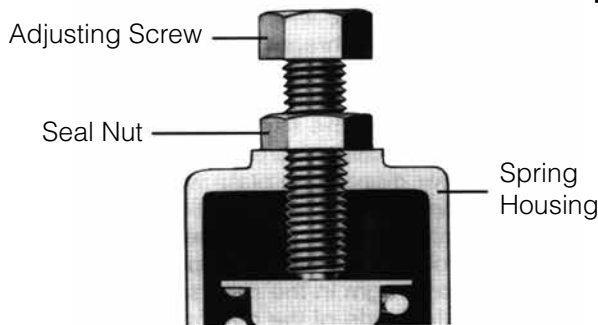

Handwheel Type

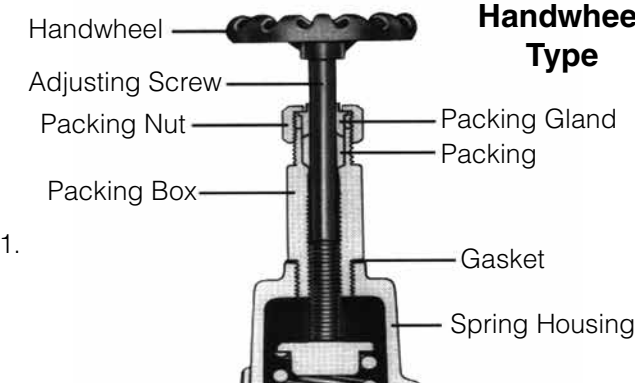

Seat Nut Type (Standard)

The seal Nut Type Differential Regulators are identical in all respects to the Mark 50 or the Mark 60 with one exception. The Seal Nut replaces the Lock Nut. Follow the instructions in the Mark 60 I & M.

Handwheel Type

1. To remove the packing, remove the Handwheel Screw and Washer from the Adjusting Screw.
2. Remove the Handwheel and then remove the Packing Nut.
3. The Packing Gland and the Packing can now be removed from the cavity of the Packing Box.
4. Teflon-impregnated, square-braided packing is recommended, but other types may be used depending upon your requirements.
5. Reassemble in reverse order.

Closing Cap Type

1. If your Differential Regulator is equipped with a Closing Cap, the only maintenance that will likely ever be required is the replacement of the gaskets.
2. To replace the gaskets, remove the Closing Cap. Then remove the Adjusting Screw and Lock Nut. The Closing Cap Bushing can then be removed. Replace the gaskets as you reassemble the valve in the reverse order.

Closing Cap Type

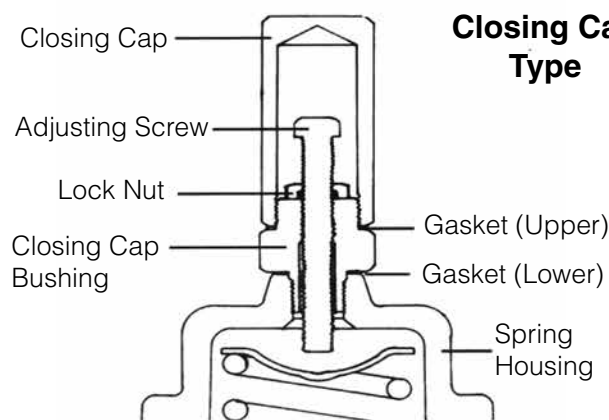

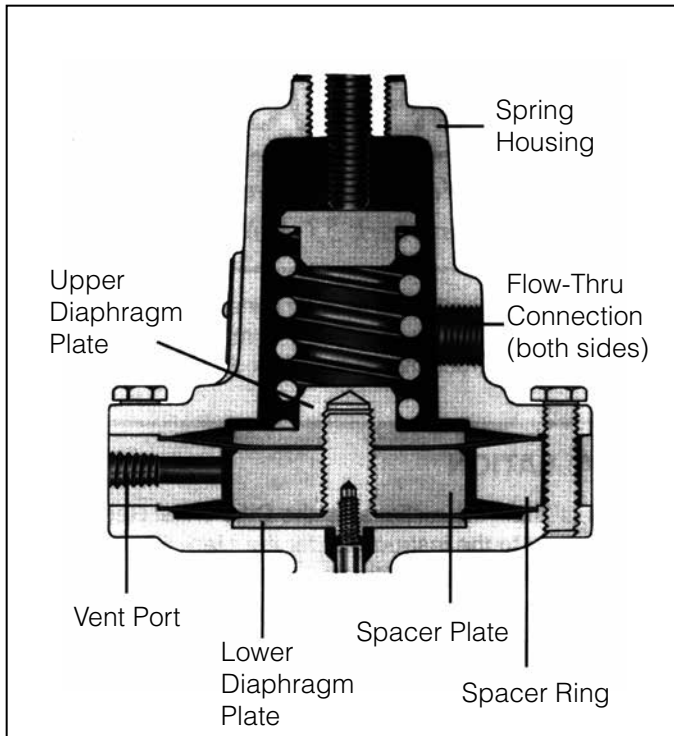

Separated Double Diaphragm

Diaphragm Replacement

1. REMOVE THE REGULATOR FROM THE LINE.
2. Release the compression of the spring by turning the adjusting screw counter-clockwise.
3. Remove the SPRING HOUSING bolts and the SPRING HOUSING, SPRING & SPRING SEAT.
4. Rotate the SPACER RING until the vent port aligns with one of the holes in the side of the spacer plate. Then bolt the spacer ring to the body with two or three bolts. Insert a metal rod through the vent port in the spacer ring and into the hole in the spacer plate. Hold securely and loosen the upper diaphragm plate with a pipe wrench.
5. Remove the upper diaphragm plate and the upper diaphragm. Then remove the spacer ring.
6. Rotate the spacer plate and diaphragm counter-clockwise and remove the assembly.
7. Fasten the spacer plate securely in a vise and then remove the lower diaphragm plate with a pin face spanner wrench. Use extreme caution, wear gloves or tap the spanner wrench with a hammer in order to avoid cutting your hands on the diaphragm.
8. Replace the diaphragm in the reverse order. Apply sealant to the fluid side of the diaphragm around the center hole and the outer seating edge. The valve stroke must be adjusted. Refer to the Mark 60 I & M for the proper instructions under the heading: DIAPHRAGM REPLACEMENT - B. ASSEMBLY AND STROKE ADJUSTMENT.