



Steriflow Food and Beverage FB5CPM Valve Series

3A Sanitary Air Loaded Pressure and Back Pressure Regulators

The FB5CPM (inlet) and FB6CPM (outlet) are air loaded sanitary constant pressure modulating valves, designed to allow the user to change setpoints remotely via a cabinet or panel mounted air regulator, or through a distributed control system or PLC, using an I-P transducer.

The CPM valve is an ideal choice for automating and maintaining constant pressure set points on the inlet side of the valve for control operations, whether they are process set points or points to fully open the valve for rinse, CIP or SIP. The valve is preferred in HTST/UHT Pasteurization, after Heat Exchangers, Separator equipment, mixing, bottling lines, etc.

FEATURES

- FB5CPM (inlet) valve automatically opens with increased flow.
- FB6CPM (outlet) valve automatically closes with increased flow.
- Compact lightweight design significantly reduces the installation space and weight if mounting the valve on a process skid.
- Permits full automation of Process, Rinse, CIP and SIP setpoints.
- Allows for constant pressure modulation when needed
- Optimized Jorlon diaphragm material, surface area and support system for unsurpassed performance and life.
- Accessory I/P or self-relieving Air regulator available for automated, and/or remote set point control
- 3A Certification 53-07

*CRN Registration Number Available For Specific Models – Contact Factory



APPLICATIONS

A wide variety of applications exist for the FB5CPM in the food, beverage, health, beauty and other industries. Processes include but are not limited to:

- HTST, UHT Process control
- Pump pressure control
- Process overpressure control
- CIP system pressure control
- Pressure bypass control
- Fill / Finish Lines
- Mixing

OPTIONS

An accessory I/P wired to a stand alone controller, PLC or DCS and an air supply will allow fully automated operation based on menu commands. Users may also opt to control the set point remotely via pneumatic tubing from a remote (panel or cabinet mounted) self-relieving instrument air regulator. Note: If using regulator we recommend the JSRLF-025 with Teflon Seat, or JSRLF-025 (EPDM seat). specified with a .2 Cv (.173 Kv) and self relieving option.



SPECIFICATIONS - FB5CPM

Sizes: 3/4" (DN20), 1" (DN25), 1 1/2" (DN40), 2" (DN50), 3" (DN80)

Wetted Material: ASME SA479 316L (UNS 31603) is standard. EN 10272:2000 GR 1.4435, AL-6XN®, Hastelloy®C-22 and others are optional.

End Connections: ASME Tri-Clamp, others consult factory

FB5CPM Cv:

Valve Size	Avail. Cv	Avail. Kv	Cv for Relief Valve Sizing	Kv for Relief Valve Sizing
3/4" (DN20)	1.5	1,3	1.8	1,56
1" (DN25)	3,0; 5,5	2,6; 4,7	5,4, 7,3	4,7; 6,4
1-1/2" (DN40)	10,0	8,6	12	10,32
2" DN50	19,0; 30,0	16,3; 26	22,8	19,56
3" (DN80)	28,0	24,1	33,6	28,9

Seat Material: Integral Hard Seat: 316L (Class IV Shutoff); Optional Seat Material: Teflon, Jorlon and Peek (all Class VI Shutoff, not 3A approved)

Actuator Housing: Air-loaded, as cast CF3M 316LSS

O-Ring Material:

- FDA and approved Teflon-Encapsulated Viton
- Optional: EPDM & Viton

Cv: Consult Factory if alternate Cvs/Kvs are required.

Diaphragm Material: Jorlon (FDA, 3A approved)

FB5CPM Min Pressure Drop: 3 psi (0,2 bar)



Optional: I/P with 4-20mA Transducer or Recommended J-Series LowFlow Regulator



Max Set Point Range:

- FB5CPM (inlet) set point range:
 - 1/2" - 1" (DN15-DN25):** 10-105 psi (0,7-7,2 bar)
 - 1-1/2" (DN40):** 10-85 psi (0,2 - 5,9 bar)
 - 2" (DN50):** 5-60 psi (0,7 - 4,1 bar)
 - 3" (DN80):** 5-60 psi (0,7 - 4,1 bar)

High Temp Valves*

Valve Size	PSIG @ 100°F (38°C)	PSIG @ 350°F (149°C)
3/4" 1" (DN20, DN25)	350 (24,1 bar)	225 (15,5 bar)
1-1/2", 2" (DN40, DN50))	200 (13,8 bar)	125 (8,6 bar)
3" (DN80)	175 (12,1 bar)	80 (5,5 bar)

* See below for 3A requirements

*3A Approved Chart

Valve Size	PSIG @ 100°F (38°C)	PSIG @ 300°F (149°C)
3/4" 1" (DN20, DN25)	350 (24,1 bar)	250 (17,2 bar)
1-1/2", 2" (DN40, DN50))	200 (13,8 bar)	200 (13,8 bar)
3" (DN80)	175 (12,1 bar)	100 (6,9 bar)

Note: Max temp for 3A/EPDM is 120°F (49°C)

O-Ring Temps:

- Buna = 225°F
- EPDM = 275°F
- Silicone = 350°F
- TFE/Viton = 350°F
- Viton = 350°F

Soft Seat Temps:

- PEEK = 350°F
- Jorlon = 300°F
- TFE = 150°F

Maximum Air Supply Pressure: 110 psi (7,6 bar)

Weight:

- 3/4" - 8 lbs (3,6 kgs) – Stainless Steel
- 1" - 8 lbs (3,6 kgs) – Stainless Steel
- 1-1/2" - 18 lbs (8,2 kgs) – Stainless Steel
- 2" - 23 lbs (10,4 kgs) – Stainless Steel
- 3" - 33 lbs (15 kgs) – Stainless Steel

FB5CPM INLET VALVE SERIES CUT-A-WAY

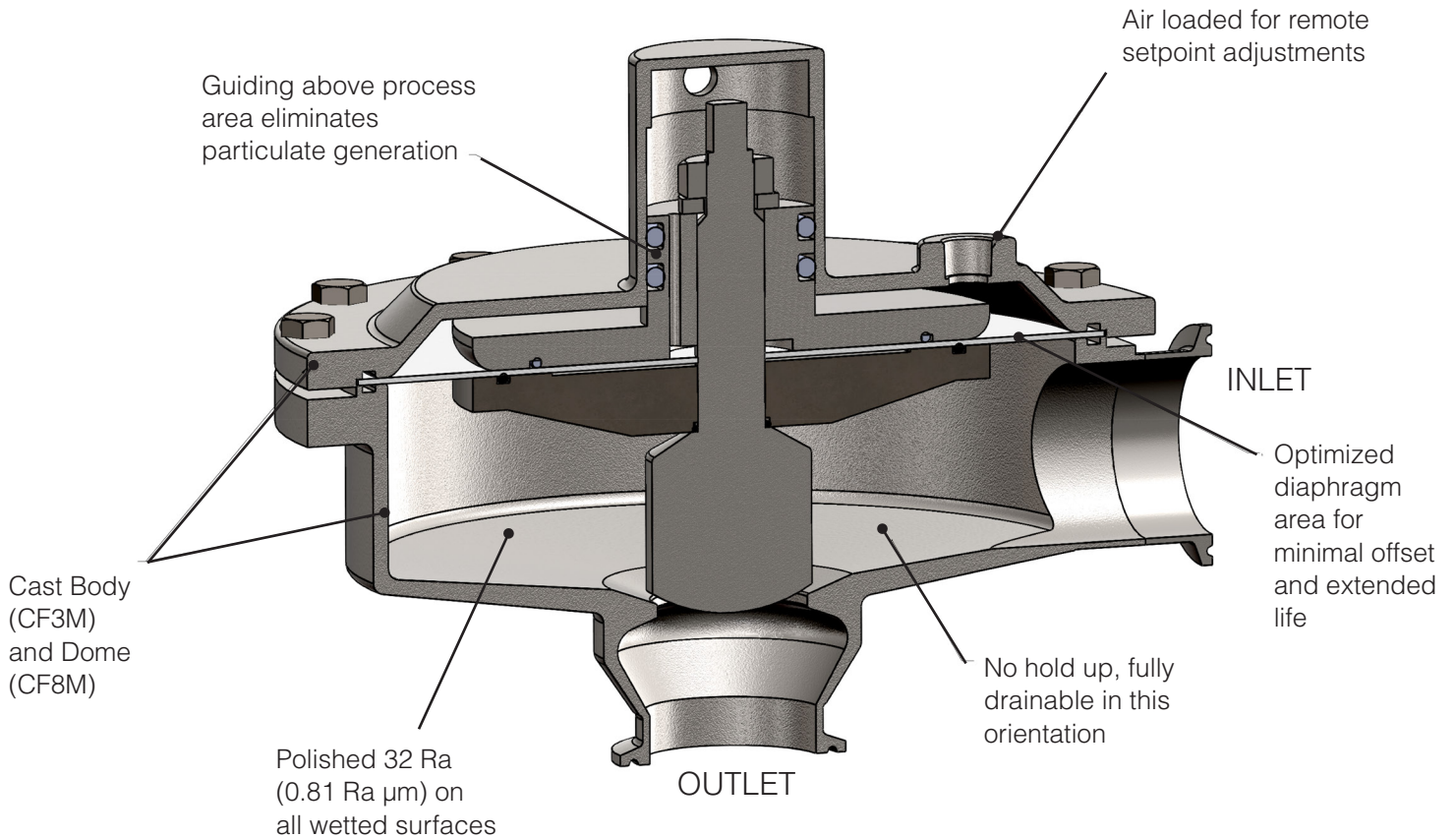

CLEAN-IN-PLACE / STEAM-IN-PLACE

To open valve for cleaning, remove the air load. The valve will open automatically once the cleaning media begins to flow. This will allow the valve to drain completely during the cleaning cycle.

WEBSITE RESOURCES

For STEP files, Installation and Maintenance Manuals, the 2019-PMO (Pasteurized Milk Ordinance) Conformity, etc. please visit our website at www.steriflowfoodandbev.com.

Installation Notes:

- As with all regulators and control valves, optimal flow performance can only be achieved with a non-turbulent flow profile. The CPM valve should be installed with 3 feet (0,9m) of straight pipe on either side of the valve.
- A pressure gauge, or transmitter reading upstream of the CPM valve should be used to make the final setpoint adjustment.

DIMENSIONS FB5CPM

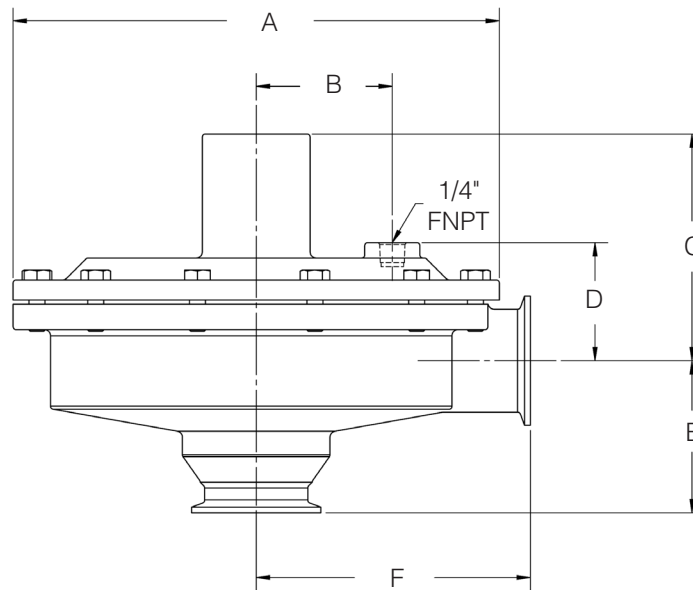

Size	Dimensions in. (mm.)					
	A	B	C	D	E	F
3/4"	5.70 (144,8)	1.38 (34,9)	2.71 (68,9)	1.63 (41,4)	1.50 (38,1)	3.29 (83,6)
1"	5.70 (144,8)	1.38 (34,9)	2.84 (72,1)	1.75 (44,5)	1.64 (41,7)	4.0 (101,6)
1-1/2"	7.22 (183,4)	1.91 (48,6)	3.79 (96,3)	1.90 (48,4)	2.53 (64,3)	4.21 (107,0)
2"	9.47 (240,5)	2.65 (67,3)	4.41 (112,1)	2.30 (58,4)	2.96 (75,2)	5.34 (135,6)
3"	9.92 (251,9)	2.65 (67,3)	5.03 (127,8)	3.02 (76,7)	3.46 (87,9)	5.37 (136,4)

CONSTANT PRESSURE MODULATING VALVE - FB5CPM (INLET) SANITARY VALVE

ORDER SCHEMATIC

Model	Size	Material	1	2	3	4	5	6	7	8	9	10	11	12
FB5CPM	—	6L												

Model	
FB5CPM	Standard (3A Approved)
FB5CPMHT	High Temp (Not 3A approved)

Size*	
75	3/4 (DN20)
100	1" (DN25)
150	1 1/2" (DN40)
200	2" (DN50)
300	3" (DN80)

Material	
6L	316L Stainless Steel

1 & 2		Body	
Finish		Cv (Kv)	
A	32 Ra (0.81 Ra µm) Interior/Cast Exterior (std)	A	1.5 (1,3)
		G	3.0 (2,6)
		K	5.5 (4,76)
		M	10 (8,65)
		N	19 (16,43)
		P	28 (24,19)
ZZ	Non-Standard		

3 & 4		Trim	
Finish		Cv (Kv) & Seat	
A	32 Ra (0.81 Ra µm)	A	1.5 (1,3) Hard Seat
		9	1.5 (1,3) Teflon Seat
		7	1.5 (1,3) PEEK Seat
		E	3.0 (2,6) Hard Seat
		F	3.0 (2,6) Teflon Seat
		G	3.0 (2,6) Jorlon Seat
		B	3.0 (2,6) PEEK Seat
		L	5.5 (4,76) Hard Seat
		M	5.5 (4,76) Teflon Seat
		N	5.5 (4,76) Jorlon Seat
		O	5.5 (4,76) PEEK Seat
		P	10 (8,65) Hard Seat
		Q	10 (8,65) Teflon Seat
		R	10 (8,65) Jorlon Seat
		3	10 (8,65) PEEK Seat

3 & 4		Trim, continued.	
Finish		Cv (Kv) & Seat	
A	32 Ra (0.81 Ra µm)	S	19 (16,43) Hard Seat
		T	19 (16,43) Teflon Seat
		U	19 (16,43) Jorlon Seat
		4	19 (16,43) PEEK Seat
		V	28 (24,19) Hard Seat
		W	28 (24,19) Teflon Seat
		X	28 (24,19) Jorlon Seat
		Y	28 (24,19) PEEK Seat

5 & 6		O-Ring/Diaphragm	
EJ	EPDM/Jorlon Diaphragm		
TY	Teflon Encapsulated Viton/Jorlon Diaphragm		
ZZ	Non-Standard		

7 & 8		I/P Or Loader Range	
Type of Loader		Max Load (PSI)	
00	None	A	J-Series 25 psi (1,7 bar)
A	4-20mA Transducer	C	J-Series 50 psi (3,4 bar)
B	J Series Loader	E	J-Series 100 psi (6,9 bar)
		P	I/P 60 psi (4,1 bar)
		H	I/P 120 psi (8,3 bar)
ZZ	Non-Standard		

9 & 10		Diaphragm	
JL	Jorlon		

11 & 12		Actuator	
AA	Standard		
ZZ	Non-Standard		

DOCUMENTATION

A Certificate of Compliance is available at no charge when requested at time of order. The "Unicert" is a chargeable document. If needed, a "Unicert" must be requested at time of order.



3170 Wasson Road • Cincinnati, OH 45209
 513.533.5600 • 800.543.7311 • 513.871.0105 (f)
 sales@richardsind.com • www.steriflowfoodandbev.com