

# 1600T SMART RTD/RESISTANCE/SLIDE WIRE SIGNAL CONDITIONER USER MANUAL

## IMPORTANT - CE & SAFETY REQUIREMENTS

Important - Potentially Hazardous situations. Persons responsible for the installation and operation of this equipment must be fully aware of all aspects of this guide. Failure to follow the instructions can cause severe injuries and damage.  
 This product is suitable for environment Installation category II pollution degree. The product is classed as "PERMANENTLY CONNECTED EQUIPMENT", and must be DIN rail mounted, inside a suitable enclosure providing environmental protection to IP65 or greater.  
 Dc supply must be derived from a local supply and not a distribution system.  
 To maintain CE EMC requirements , input and supply wires must be less than 30 metres. The product contains no serviceable parts , or internal adjustments. No attempt must be made to repair this product. Faulty units must be returned to supplier for repair. This product must be installed by a qualified person. All electrical wiring must be carried out in accordance with the appropriate regulations for the place of installation. Before attempting any electrical connection work, please ensure all supplies are switched off.

ABSOLUTE MAXIMUM CONDITIONS ( To exceed may cause damage to the unit):-  
 Supply Voltage ± 50 V dc (Protected for over voltage and reverse connection)  
 Current with over voltage ± 200 mA  
 Input Voltage ± 24 VDC, 24 V rms between any terminals  
 Input Current ± 30 mA between terminals  
 Ambient Temperature (-30 to 75) °C Humidity (10 to 95) % RH (Non condensing)



PLEASE REFER TO THE PRODUCT LABEL FOR MANUFACTURERS CONTACT DETAILS.

Every effort has been taken to ensure the accuracy of this document, however we do not accept responsibility for damage, injury, loss or expense resulting from errors and omissions, and we reserve the right of amendment without notice.

## RECEIVE AND UNPACKING

Please inspect the packaging and instrument thoroughly for any signs of transit damage. If the instrument has been damaged, please notify your supplier immediately.

## OPERATION (please refer to data sheet for full technical specification.)

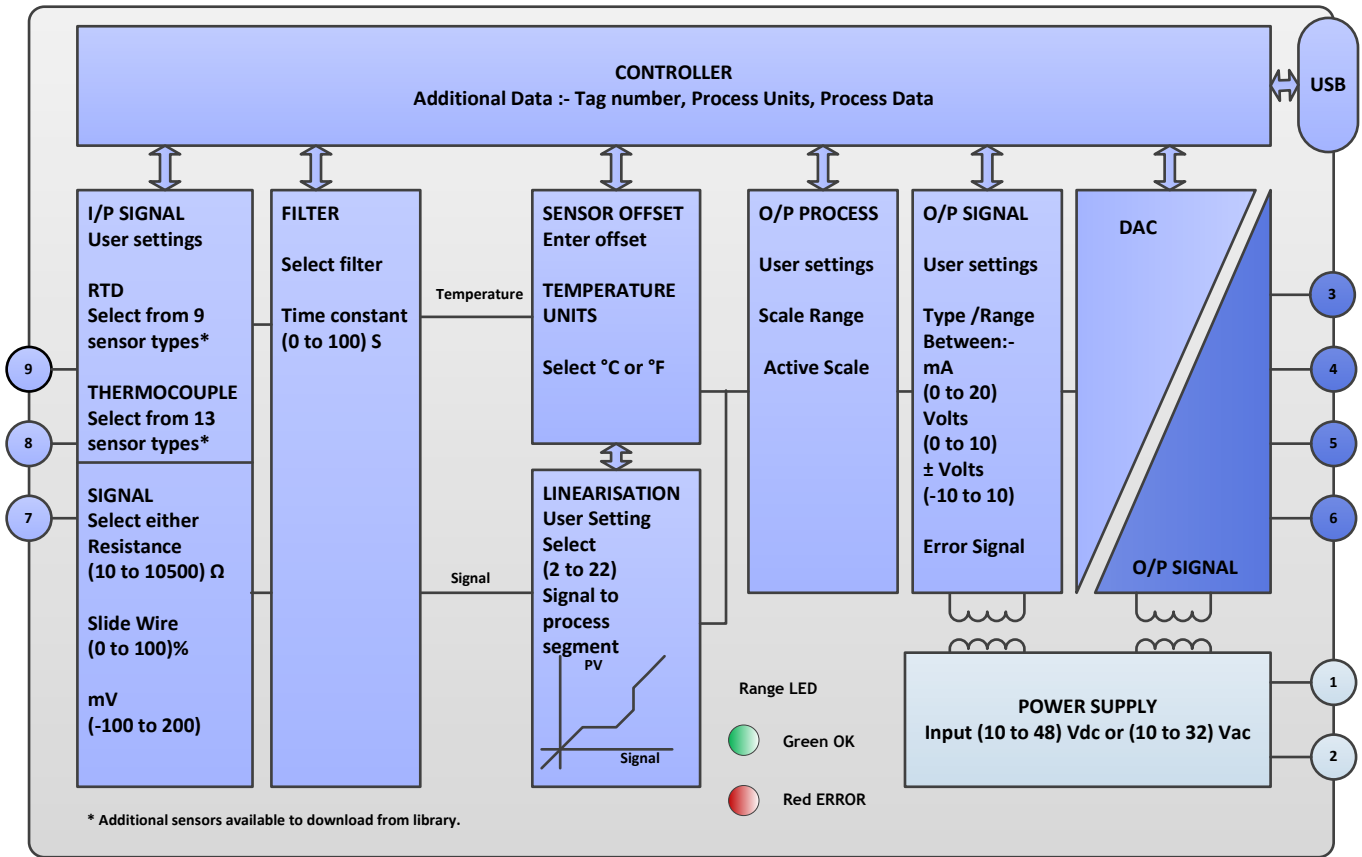

\* Additional sensors available to download from library.

## CONFIGURATION

This product is configured using the USB port of a PC running USB\_Speed\_Link software, available from your suppliers web site. During configuration the product is powered direct from the usb port, removing the need for additional power. If the user wishes to monitor live process data during configuration, then powered must be applied. Note the input and USB port of the device share the same ground, therefore care must be taken to ensure isolation between PC and input circuit. This is best achieved by using a portable laptop or notebook PC. USB\_Speed\_Link software is provided with detailed help menu to guide the user through the simple configuration procedure. Unless specified at the time of order this product is supplied with the default configuration listed below.



**Factory default:**  
 Input Type = PT100 (IEC)  
 Input Range = (-205 to 855) °C  
 Units = " C "  
 Process Output = (0 to 100) °C  
 Output range = (4 to 20) mA  
 Filter = off  
 User offset = 0.0 °C  
 Tag = " "  
 Error Signal = 21.00 mA

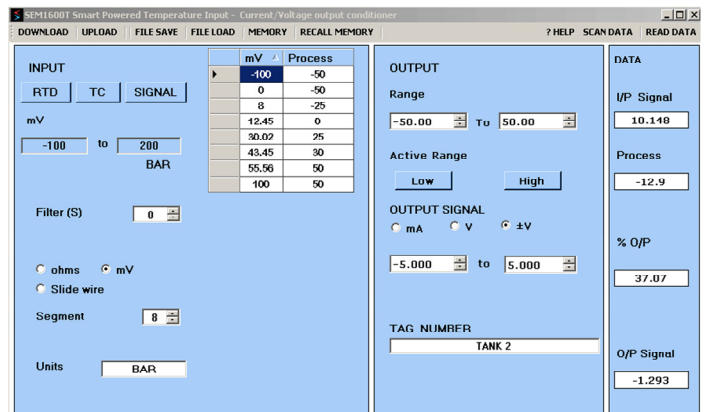



## MECHANICAL INSTALLATION

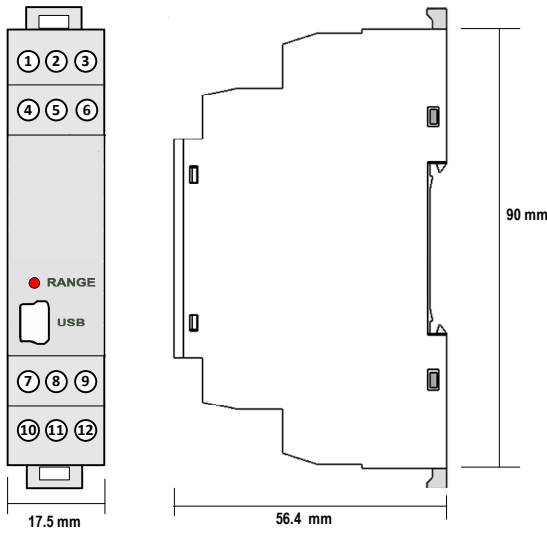

Style DIN 43880 (1 module width)  
 Material Polyamide 6.6 self extinguishing  
 Terminals Screw terminal  
 Cable 2.5 mm Max  
 Colour Grey

## MOUNTING

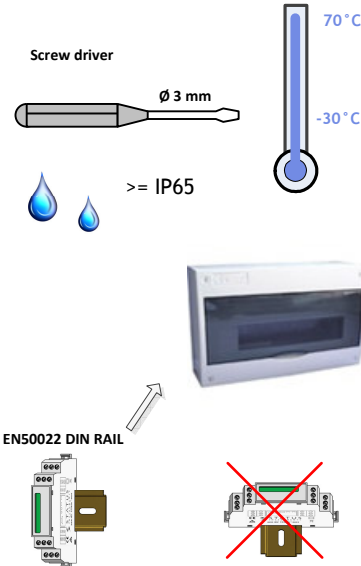

## TOP

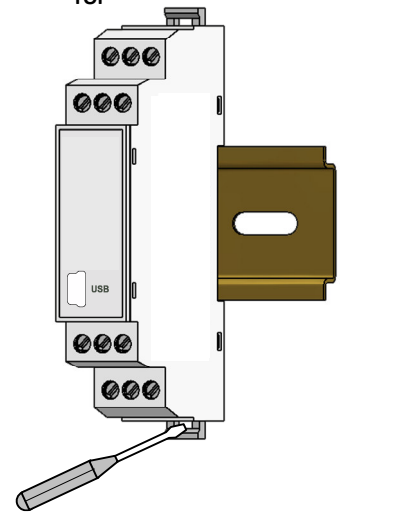

To fit or release module  
 Insert screw driver into slot and lever latch away from body



## ELECTRICAL INSTALLATION

- 1.0 TURN OFF SUPPLY BEFORE WORKING ON ANY ELECTRICAL CONNECTION.
- 2.0 SUPPLY IS OVER VOLTAGE PROTECTED AND FUSED WITH INTERNAL RESETTABLE FUSE.

## CONNECTION

For cable length < 3 Metres no screen or twist pair required.  
 Use recommended types for cable length (3 to 30) metres.

### Input Wires

Resistance slide  
 thermocouple wire  
 Screened Cable



### Output Wires

Screened cable or  
 twisted pair

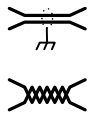

### Note:

Open circuit signal detection is not available on mV Input (Pins 7 & 8).

Short circuit, mV Input (Pins 7 & 8) will read 0 mA at Input

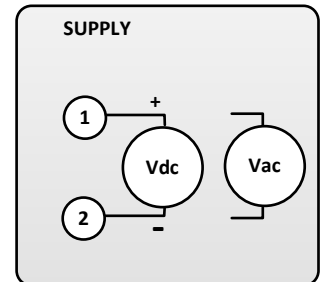
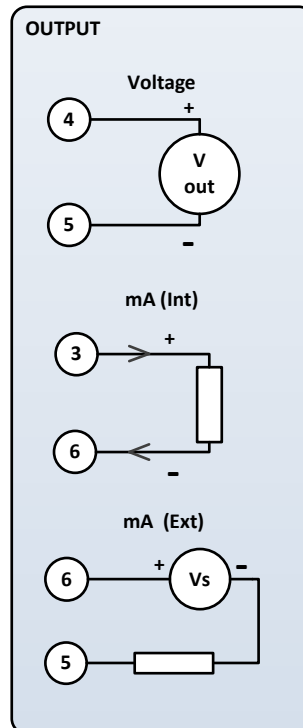
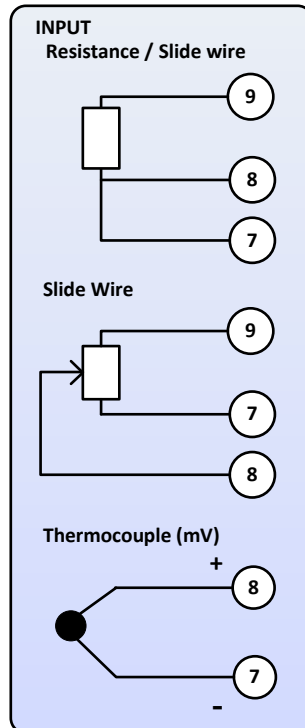

Screw Driver

